



# VMG SERIES MANUAL CONTROL HEAVY-DUTY GAS GRIDDLE



Model VMG36



## SPECIFICATIONS

Low profile heavy duty gas griddle, Vulcan model No. \_\_\_\_\_ Stainless steel front, sides, and front top ledge. Fully welded stainless and aluminized steel body frame. 11" low profile cooking height on 4" legs. 1" thick polished steel griddle plate with 12 gage, 4" stainless steel back and tapered side splashes. Grease chute is fully welded to stop grease migration. One 27,000 BTU/hr. "U" shaped aluminized steel burner for every 12" of griddle width. One high range infinite heat control valve per burner. 3½" wide stainless steel grease trough. ¾" rear gas connection and pressure regulator.

### Exterior Dimensions:

\_\_\_\_\_ "W x 31½"D x 15½"H on 4" legs

**SPECIFY TYPE OF GAS WHEN ORDERING.**

**SPECIFY ALTITUDE WHEN ABOVE 2,000 FT.**

Project \_\_\_\_\_

AIA # \_\_\_\_\_ SIS # \_\_\_\_\_

Item # \_\_\_\_\_ Quantity \_\_\_\_\_ C.S.I. Section 114000

## MODELS

- VMG24** 24"W x 24"D griddle plate
- VMG36** 36"W x 24"D griddle plate
- VMG48** 48"W x 24"D griddle plate
- VMG60** 60"W x 24"D griddle plate
- VMG72** 72"W x 24"D griddle plate

## STANDARD FEATURES

- Stainless steel front, sides, and front top ledge with "Cool Bullnose" design
- Fully welded stainless and aluminized steel chassis frame
- 11" low profile cooking height on 4" adjustable legs
- 1" thick polished steel griddle plate with 12-gauge, 4" stainless steel back and tapered side splashes
- Spatula wide 3½" grease gutter and grease chute is fully welded for easier cleaning and to stop grease migration
- One 27,000 BTU/hr. "U" shaped aluminized steel burner for every 12" of griddle width
- Large 6 quart stainless steel grease drawer (2 drawers on 60" and 72" models)
- One high range infinite heat control valve per burner
- Bottom heat shields
- Standing pilot ignition system
- ¾" rear gas connection and pressure regulator
- One year limited parts and labor warranty

## OPTIONAL FEATURES

- Stainless steel stand with marine edges and casters
- Cutting board, condiment rail, plate rail, and banking strip accessories
- Full or partially grooved griddle plate

VMG SERIES - HEAVY DUTY MANUAL GAS GRIDDLE

Approved by \_\_\_\_\_ Date \_\_\_\_\_ Approved by \_\_\_\_\_ Date \_\_\_\_\_

### INSTALLATION INSTRUCTIONS

1. A gas pressure regulator supplied with the unit must be installed;  
Natural Gas 4.0" (102 mm) W.C.  
Propane Gas 10.0" (254 mm) W.C.
2. An adequate ventilation system is required for commercial cooking equipment. Information may be obtained by visiting the National Fire Protection Association website at <https://www.nfpa.org/>. Refer to NFPA No. 96.
3. These units are manufactured for installation in accordance with ANSZ223.1A (latest edition), National Fuel Gas Code. Information may be obtained from The American Gas Association website at <https://www.aga.org/>.

**NOTE: In The Commonwealth of Massachusetts**

All gas appliances vented through a ventilation hood or exhaust system equipped with a damper or with a power means of exhaust shall comply with 248 CMR.

4. Clearances:
 

	Combustible	Non-Combustible
Rear	6"	0"
Sides	6"	0"
5. This appliance is manufactured for commercial installation only and is not intended for home use.

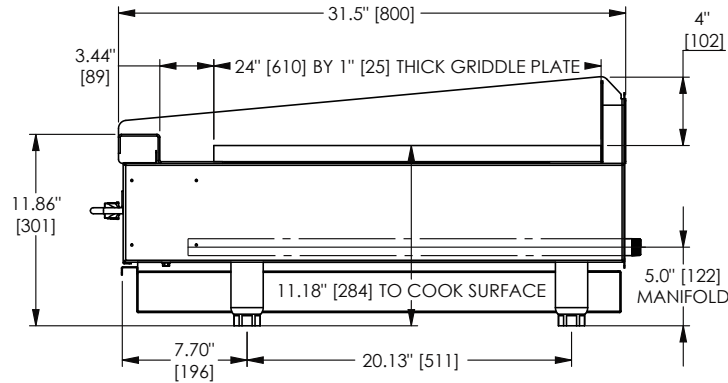
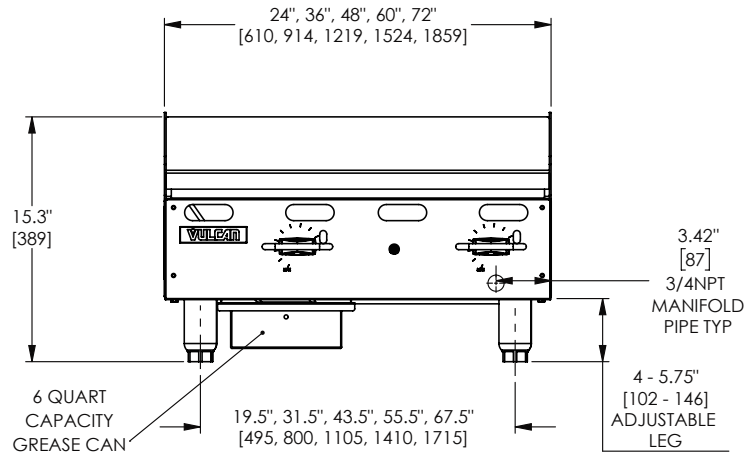

MODEL	WIDTH	DEPTH	OVERALL HEIGHT*	WORKING HEIGHT*	NO. OF BURNERS	TOTAL BTU/HR.	NO. OF DRAWERS	APPROX. SHIP. WT.
VMG24	24"	31½"	15¼"	11⅞"	2	54,000	1	285 lbs./129 kg.
VMG36	36"	31½"	15¼"	11⅞"	3	81,000	1	400 lbs./181 kg.
VMG48	48"	31½"	15¼"	11⅞"	4	108,000	1	480 lbs./218 kg.
VMG60	60"	31½"	15¼"	11⅞"	5	135,000	2	650 lbs./295 kg.
VMG72	72"	31½"	15¼"	11⅞"	6	162,000	2	790 lbs./358 kg.

\*These are nominal dimensions and can vary by +1.75" with adjustable legs.

As continued product improvement is a policy of Vulcan, specifications are subject to change without notice.