

COMBI

VULCAN**MINIJET
ELECTRIC BOILERLESS COMBI OVEN STEAMER**

Model MINI-JET



The Minijet was tested for Ventless Grease Laden Vapor Approval by UL in accordance with EPA test method 202 resulting in grease-laden effluents collected at just 1.52 mg/m³, less than the 5.0 mg/m³ limit without the need for an additional system or listing. Certification for Commercial Cooking Appliances with Integral Systems for Limiting the Emission of Grease-laden Air (KNLZ) also apply to the Minijet or stacked Minijets using optional MINI-HOOD1 or MINI-HOOD2. Local codes prevail.

SPECIFICATIONS

Vulcan MINI-JET Combi Oven Steamer, Electric, Boilerless, Left or Right hinged door, hotel pan capacity of (4) 12" x 20" x 2.5" or (6) 12" x 20" x 1" or (6) 13" x 18" x 1" half sheet pans. Multiple cooking capabilities from one piece of equipment: Baking, Steaming, Roasting, Grilling, Air-Fry, Rethermalization, Proofing, Finishing, Poaching, Stewing, Low Temp, Defrosting, Cook & Hold, and more. Twin Control via capacitive LCD touch screen & coding turn/push knob. User Interface including Manual displays for ABC, JET or ECO operator functions. ABC Interface adjusts humidity automatically after setting temperature. AUTO Interface featuring preloaded and programmable recipes with picture or text display. My Recipes, My Favorites, Multi-Level Shelf Timers and Multi-Product interface functions. Toolbox Interface for Manual & Auto Cleaning wash system, custom setting of parameters, visual & interactive service diagnostics, data collection with operator instructions and video training directly from LCD display. Auto-reversing fan, LED light strip with flashing identification in cool touch door, USB & food probe port, 4" legs, detergent hose, drain water tempering. Pull out control panel drawer for service access from front. All units ship 208v/60/3 phase wiring with 6' cord and L15-30P NEMA plug. Field convertible to 208/60/1, 240/60/1, or 240/60/3. One year limited parts and labor warranty.

- MINI-JET (V2MF061E-86)
- MINI-JETR (V2MF061E-86FD)

STANDARD FEATURES

- Multiple cooking capabilities from one piece of equipment: Baking, Steaming, Roasting, Grilling, Air-Fry, Rethermalization, Proofing, Finishing, Poaching, Stewing, Low Temp, Defrosting, Cook & Hold, and more.
- Boilerless combi which uses direct steam creation for optimized cooking capability and production with minimal energy and water consumption using CoreControl power management.
- Pan Capacity of (4) 12" x 20" x 2.5" or (6) 13" x 18" x 1" pans.
- Twin Control via LCD capacitive touch screen display & coding turn/push knob.
- User Interface including Manual displays for ABC, JET or ECO operator functions. ABC automatically adjusts humidity after setting temperature. ABC & JET features always on function, no start button to activate. JET for manual convection, steam and combi settings. ECO for required start button activation providing maximum energy savings.
- AUTO Interface featuring 80+ preloaded and programmable recipes with text or picture display. Additional AUTO options with My Recipes, My Favorites, Multi-Level Shelf Timers and Multi-Product interface functions.
- Toolbox for Manual or Auto Cleaning wash system, custom settings for user personalization, visual interactive service diagnostics, and operator instructions with video training directly from LCD display.
- Temperature: 80-482°F with visual display of Set and Actual.
- Timer: continuous (---) up to 99:00 hours and minutes with set, remaining or count time displayed. Timer reloads for batch cooking after completion of timed cycle (ABC).
- Humidity range: 0-100%
- Auto-reversing fan with speed control adjustment
- Flashing LED lights & audible alarm system alert user when cooking cycle finished.
- PC Software available for free download that matches machine functions allowing for transfer of recipes, photographs and profiles via USB.
- One year limited parts and labor warranty (two-year K-12).

OPTIONS

- Hollow Carbon Filter System – Good
 - CB15K-SYSTEM – 15,000 gal. (carbon only treatment)
 - CB30K-SYSTEM – 30,000 gal. (carbon only treatment)
- Water Softening – Better (Carbon CBK System Required)
 - WS-40 - 40 lb. capacity (hard water treatment)
- Reverse Osmosis (RO) System – Best
 - V3MRO-1 up to 100 gpd capacity, single unit
 - V3MRO-2 up to 200 gpd capacity, double unit
- Second year extended limited parts and labor warranty contract.

ACCESSORIES (Packaged & Sold Separately)

- | | |
|--------------------------------------|--|
| <input type="checkbox"/> MINI-STAND | <input type="checkbox"/> STACK-MINI/CONV |
| <input type="checkbox"/> MINI-STACK | <input type="checkbox"/> MINI-SPRAY |
| <input type="checkbox"/> MINI-STACK2 | <input type="checkbox"/> MINI-RACK |
| <input type="checkbox"/> MINI-PROBE3 | <input type="checkbox"/> 1220-BASKET |
| <input type="checkbox"/> MINI-HOOD1 | <input type="checkbox"/> 1220-GRILLOP |
| <input type="checkbox"/> MINI-HOOD2 | <input type="checkbox"/> HOSEWTR 3/4BBV |

VULCAN

a division of ITW Food Equipment Group LLC

P.O. Box 696 ■ Louisville, KY 40201 ■ Toll-free: 1-800-814-2028 ■ Local: 502-778-2791 ■ Quote & Order Fax: 1-800-444-0602



MINIJET ELECTRIC BOILERLESS COMBI OVEN STEAMER

WATER QUALITY STATEMENT:

The fact that a water supply is potable is no guarantee that it is suitable for steam generation. All steam equipment is subject to contamination and failure due to chemical and mineral content found in water. A suitable Water Treatment System and regular filter replacements coupled with routine deliming is the recommended minimum. Damage as a result of poor water quality or lack of required owner/operator maintenance is the responsibility of the owner/operator.

Your water supply must be within these general guidelines:

DYNAMIC WATER PRESSURE	30 - 80 psig
HARDNESS*	1 - 3 grains
SILICA	less than 13 ppm
TOTAL CHLORIDE	less than 30 ppm
pH RANGE	7-8
CHLORINE & CHLORAMINE	0 ppm
ALKALINITY	less than 20 ppm
TDS	less than 60 ppm
UN-DISSOLVED SOLIDS	less than 5 microns

* 17.1 ppm = 1 grain of hardness

Other factors affecting steam generation are iron content, amount of chlorination and dissolved gases. Water supplies vary from state to state and from locations within a state. Therefore it is necessary that the local water treatment specialist be consulted before the installation of any steam generating equipment (Ask your rep for a free water test).

SERVICE CONNECTIONS:

Water: Filtered and Unfiltered cold water line female connections into 3/4" male NSHT (50-60 psi recommended for best results).

Drain: 1 1/4" diameter unthreaded adjustable copper elbow included with unit. Drain tempering below 140° via cold unfiltered water connection.

Electrical: 208v/60/3 standard with 6' cord and L15-30P NEMA plug. Field convertible to 208/60/1, 240/60/1, or 240/60/3.

MODEL	PH	208V		240V	
		KW	AMP	KW	AMP
Minijet	1	5.2	25	6.83	28.5
	3	5.2	14.9	6.83	16.8

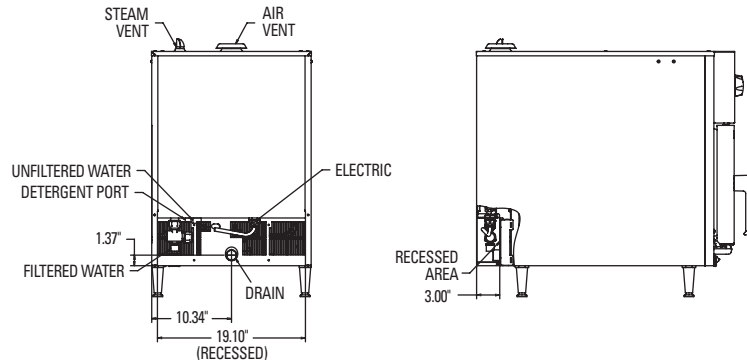
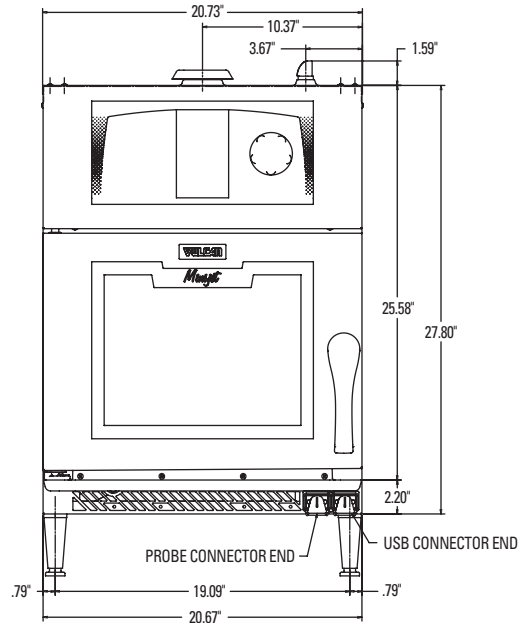
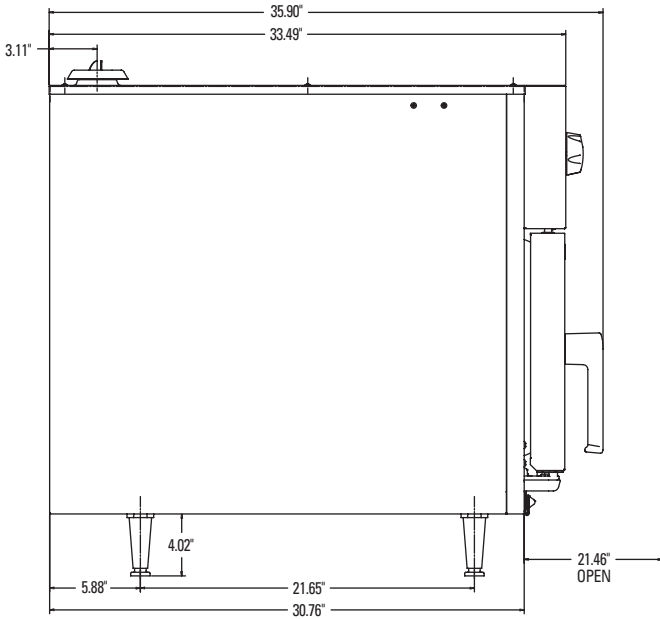

Capacity: Cooking cavity fitted with thirteen runners spaced at .87" (22mm) capable of pan capacity: (4) 12" x 20" x 2.5", (6) 12" x 20" x 1" hotel pans or (6) 13" x 18" x 1" half sheet pans.

Clearance: 0" (Left, Back, Right) External heat sources from other equipment may require space or heat shield.

Machine Weight: 163 lbs. (shipping weight 196 lbs.)

NOTE: Water is a customer supplied utility just like Gas and Electric to the equipment. Water tests are recommended.



a division of ITW Food Equipment Group LLC

P.O. Box 696 ■ Louisville, KY 40201 ■ Toll-free: 1-800-814-2028 ■ Local: 502-778-2791 ■ Quote & Order Fax: 1-800-444-0602

NOTE: In line with its policy to continually improve its products, Vulcan reserves the right to change materials and specifications without notice.