

## S T E A M

**VULCAN****KDL SERIES  
DIRECT STEAM FLOOR MOUNTED  
STATIONARY 2/3 JACKETED KETTLE**

Model K20DL shown with optional 2" plug valve



ANS/NSF Standard #4

**SPECIFICATIONS**

Direct steam, stainless steel, 2/3 jacketed floor mounted stationary steam kettle. Ellipsoidal bottom kettle liner formed and fully welded type 316 and type 304 stainless steel exterior with (1/4 x 5/8 inch 20 gallons) (3/8 x 1 inch 40 gallons and greater) bar rim, embossed gallon/liter markings and faucet bracket. 50 psi (3.4 kg/cm<sup>2</sup>) steam jacket rating. Spring assist hinged stainless steel cover with condensate ring and drop down lift handle with heavy duty pivot assembly that includes a yolk style mount with tie bar. Two inch compression tangent draw-off valve with perforated strainer. Tubular stainless steel legs with flanged feet. Steam control assembly includes condensate return line strainer and, safety valve steam trap.

UL Classified for sanitation in accordance with ANSI/NSF Standard #4. Meets ASME code.

- K20DL** 20 gallon true working capacity
- K40DL** 40 gallon true working capacity
- K60DL** 60 gallon true working capacity

**STANDARD FEATURES**

- Direct steam, stainless steel, 2/3 jacketed floor mounted stationary steam kettle.
- Ellipsoidal bottom kettle liner formed and fully welded standard type 316 and type 304 stainless steel exterior.
- Heavy bar rim (1/4 x 5/8 inch 20 gallons) (3/8 x 1 inch 40 gallons and greater).
- Embossed gallon/liter markings.
- Faucet bracket.
- 50 psi (3.4 kg/cm<sup>2</sup>) steam jacket rating.
- Spring assist hinged stainless steel cover with condensate ring and drop down lift handle with heavy duty pivot assembly that includes a yolk style mount with tie bar.
- Two inch compression tangent draw-off valve with perforated strainer.
- Tubular stainless steel legs with flanged feet.
- Steam control assembly includes condensate return line strainer and, safety valve steam trap.
- One year limited parts and labor warranty.

**OPTIONS**

- Two inch plug tangent draw-off valve with perforated strainer.
- Three inch compression tangent draw-off valve with perforated strainer.
- Security facility package:
  - a. Security type tamper resistant fasteners with tack welds.
  - b. Stainless steel step cover over draw-off valve with chain.
- Second year extended limited parts and labor warranty.

**ACCESSORIES (Packaged & Sold Separately)**

- Clean-up kit, includes draw-off brush, clean-up brush and paddle scraper with 40" handle.
- Stainless steel 48" whip.
- Solid disk.
- 12" riser (18" double jointed) single pantry lead-free faucet.
- 12" riser (18" double jointed) double pantry lead-free faucet.
- Double pantry washdown hose with 16" add-on lead-free faucet with vacuum breaker.
- Double pantry washdown hose with vacuum breaker.
- Double pantry pot filler and vacuum breaker.

**VULCAN**

a division of ITW Food Equipment Group LLC

P.O. Box 696 ■ Louisville, KY 40201 ■ Toll-free: 1-800-814-2028 ■ Local: 502-778-2791 ■ Quote &amp; Order Fax: 1-800-444-0602



## KDL SERIES DIRECT STEAM FLOOR MOUNTED STATIONARY 2/3 JACKETED KETTLE

### SERVICE CONNECTIONS

- Steam supply:** 3/4" IPS.
- Condensate return:** 1/2" IPS.

### TRUE WORKING CAPACITIES (in 4 oz. servings)

80 quarts/20 gallons/76 liters/640 servings  
 160 quarts/40 gallons/152 liters/1,280 servings  
 240 quarts/60 gallons/228 liters/1,920 servings

### NOTE

- Dimensions which locate the above connections have a tolerance of + or -3" (+ or -77 mm).
- Installation of backflow preventers, vacuum breakers and other specific code requirements is the responsibility of the owner and installer. It is the responsibility of the owner and installer to comply with local codes.
- This appliance is manufactured for commercial installation only and is not intended for home use.

### DIRECT STEAM DATA

- Steam supply to the kettles must:
1. Maintain a steady 10 psi flow under operating conditions.
  2. Have a minimum flow (see chart) of dry steam.
  3. Be adequately trapped to provide dry steam. (See ball float trap.)

### STEAM FLOW RATE AT 10 PSIG AT THE KETTLE

	Fast Boil		Medium Boil		Slow Boil	
	lbs/hr	kg/hr	lbs/hr	kg/hr	lbs/hr	kg/hr
20 gallon	48	22	32	15	24	11
40 gallon	88	40	70	32	44	20
60 gallon	132	60	105	48	66	30

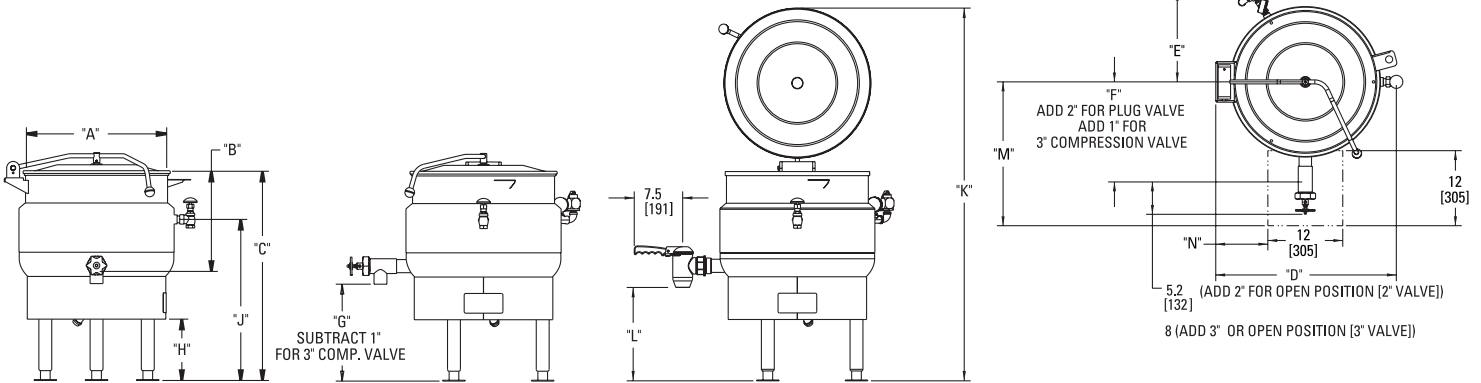

MODEL	TRUE WORKING CAPACITY	A	B	C	D	E	F	G	H	J	K	L	M	N
K20DL	20 gallons	21.6	15.2	31.86	28.8	15.7	16	14.7	9.3	24.5	56.75	14.3	23	8.3
	76 liters	549	386	809	732	399	406	373	236	622	1441	363	586	211
K40DL	40 gallons	25.8	21.2	37.1	32.9	17.5	17.7	14	10.5	25	66	13.5	24.8	10.5
	152 liters	656	538	942	836	445	450	356	267	635	1676	343	632	267
K60DL	60 gallons	29.5	23.9	39.4	36.9	19.3	19.7	13.5	8	26.5	72.5	13	27.5	12.2
	227 liters	749	607	1001	937	490	500	340	203	673	1842	330	700	310



a division of ITW Food Equipment Group LLC

P.O. Box 696 ■ Louisville, KY 40201 ■ Toll-free: 1-800-814-2028 ■ Local: 502-778-2791 ■ Quote & Order Fax: 1-800-444-0602

**NOTE:** In line with its policy to continually improve its products, Vulcan reserves the right to change materials and specifications without notice.