

RESTAURANT RANGES**VULCAN****12" ELECTRIC
RESTAURANT RANGE**

Model EV12-2FP208
shown with adjustable legs



- EV12-2FP208** 2 French Plates / 208V
- EV12-2FP240** 2 French Plates / 240V
- EV12-2FP480** 2 French Plates / 480V
- EV12-1HT208** 1 Hot Top / 208V
- EV12-1HT240** 1 Hot Top / 240V
- EV12-1HT480** 1 Hot Top / 480V

STANDARD FEATURES

- Fully MIG welded aluminized steel frame for added durability
- Stainless steel front, sides, back riser and legs
- Fully enclosed 31" high body with removable front panel
- Two 9½" round, 2 KW French plates with infinite heat control switches
- 6" stainless steel adjustable legs
- Requires 208, 240 or 480 volt, 1 or 3 phase power supply. (Ranges shipped in 3 phase and are field convertible to single phase)
- One year limited parts and labor warranty

SPECIFICATIONS

12" wide electric restaurant range, Vulcan Model No. EV12-2FP208. Fully MIG welded aluminized steel frame for added durability. Stainless steel front, sides, back riser, and 6" adjustable legs. Two 9½" round, 2 KW French plates with infinite heat control switches on 208 and 240 volt units. Each 9½" round casting is rated 2000 watts at either 208, 240 or 480 volts. On 480 volt units each casting is controlled by a 4 position heat switch. Vulcan Model No. EV12-1HT-208, includes one 12" x 24" 5 KW cast hot top that is thermostatically controlled. Hot top not suitable for griddle work. Hot top available in single phase only.

Exterior Dimensions:

34"d x 12"w x 37"h on 6" adjustable legs

VULCAN

a division of ITW Food Equipment Group LLC

P.O. Box 696 ■ Louisville, KY 40201 ■ Toll-free: 1-800-814-2028 ■ Local: 502-778-2791 ■ Quote & Order Fax: 1-800-444-0602



12" ELECTRIC RESTAURANT RANGE

INSTALLATION INSTRUCTIONS

Clearances from Combustible Construction

	Rear	Sides
Range with French Plates	0"	3"
Range with Griddle Tops	0"	3"
Range with Hot Tops	0"	6"

Ranges with an ESB Salamander Broiler mounted above:
Refer to the ESB Salamander Broiler spec sheet for clearance specifications.

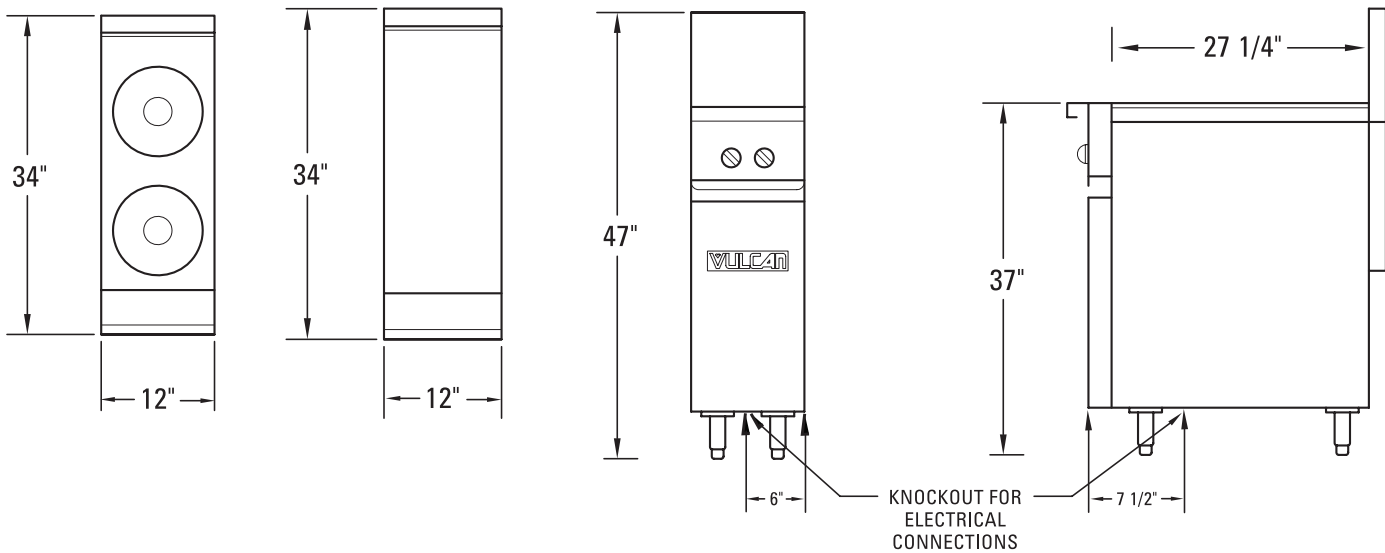

208 OR 240 VOLT									
MODEL	TOTAL CONN. KW	LOAD KW PER PHASE							
		3-PHASE							
		L1 - L2			L2 - L3			L1 - L3	
EV12-2FP208	4	2.0			2.0			--	
EV12-2FP240	4	2.0			2.0			--	
NORMAL AMPS PER LINE									
3 PHASE									
1 PHASE									
208V			240V			208V	240V		
L1	L2	L3	L1	L2	L3	L1 - L2	L1 - L2		
EV12-2FP208	4	9.6	17.3	9.6	--	--	--	20.3	--
EV12-2FP240	4	--	--	--	7.3	14.5	7.3	--	16.7
EV12-1HT208	5	--	--	--	--	--	--	24.0	--
EV12-1HT240	5	--	--	--	--	--	--	--	20.8

480 VOLT					
MODEL	TOTAL CONN. KW	LOAD KW PER PHASE			
		3-PHASE			
		X - Y	Z	Y - Z	
EV12-2FP480	4	2.0	2.0	--	
NORMAL AMPS PER LINE					
3 PHASE					
1 PHASE					
480V					
480V					
X	Y	Z	X - Z		
EV12-2FP480	4.0	3.6	7.3	3.6	8.3
EV12-1HT480	5	--	--	--	10.4

This appliance is manufactured for commercial use only and is not intended for home use.



a division of ITW Food Equipment Group LLC

P.O. Box 696 ■ Louisville, KY 40201 ■ Toll-free: 1-800-814-2028 ■ Local: 502-778-2791 ■ Quote & Order Fax: 1-800-444-0602

NOTE: In line with its policy to continually improve its products, Vulcan reserves the right to change materials and specifications without notice.